

DIY Kit - Awesome Wall-mounted Digital Electronic LED Watch - “Female whim”

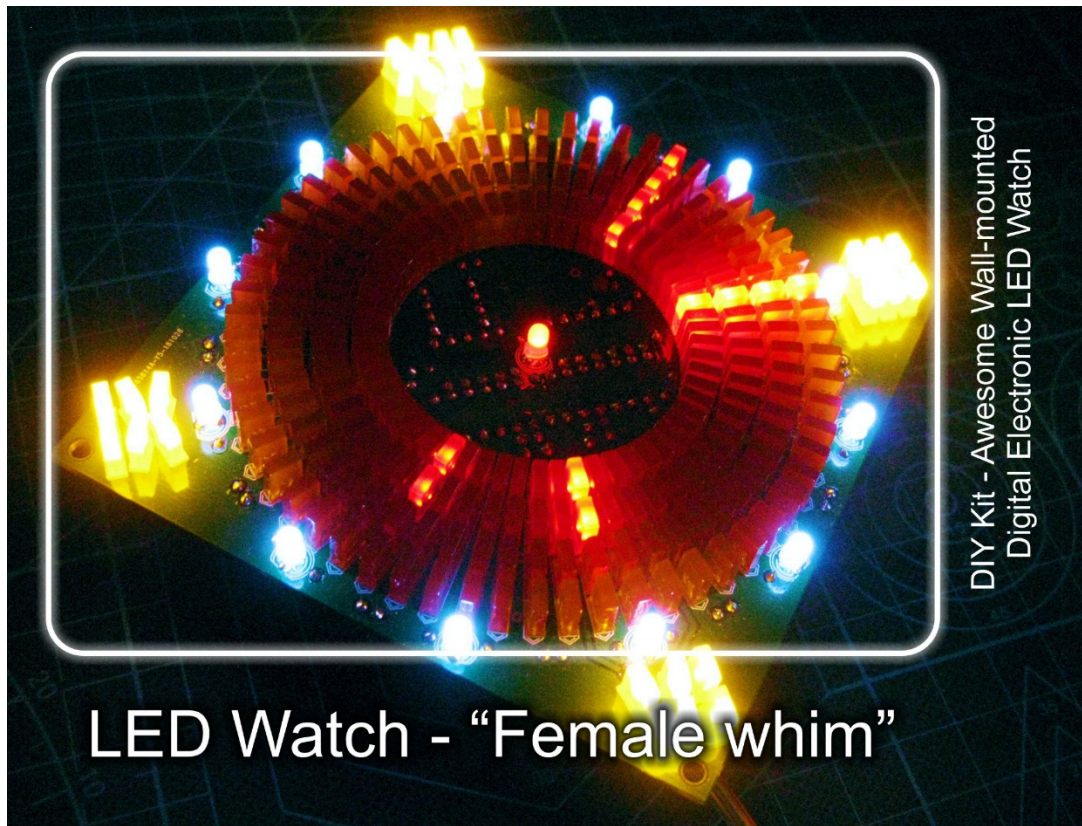

Electronic designer for self-assembly of LED watches!

Manual for self-assembly. We strongly recommend that you study before starting assembly work!

Contents:

Equipment:.....	2
Labeling and list of components.	2
Assembly instruction.....	4
Designation of components in the circuit board illustration:.....	4
Active components:	10
Watch dial LEDs:.....	10
Time setting.	11
Attention!.....	11
Possible causes of malfunction.	12
If the arrows do not light, the problem is in the controller.	12
P.S.....	12
Application 1.	12

Equipment:



Labeling and list of components.

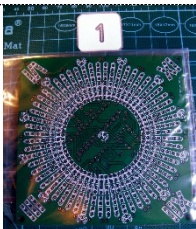

PCB 100x100mm double-sided - 1 pc.



CR1220 battery holder (battery not included) - 1 pc.



Resistor 100 Ohm 0,125w CFR - 15pcs.
Resistor 300 Ohm 0,125w CFR - 13sht.
Resistor 4,7 kOhm 0,125w CFR - 2 pcs.
Resistor 10 kOhm 0,125w CFR - 2 pcs.
Resistor 20 kOhm 0.125w CFR - 12 pcs.

Microcontroller ATMEGA8-16PU (with firmware) - 1 pc.
Real-time clock chip DS1307 - 1 pc.

Rectangular LEDs 2x5x7mm red for the dial - 240 pcs.

USB Type A connector, 4 pins - 1 pc.

Round 3mm LEDs white for hour markers - 12 pcs.

Rectangular LEDs 2x5x7mm yellow for the dial - 26 pcs.

Ceramic capacitor CT4 0.1uF 50V - 3 pcs.
Button tact TACT 6x6-5.0 - 1 pc.
Round 3mm LED red for the clock axis - 1 pc.
Quartz resonator 32768Hz HC 3 * 8 - 1 pc.

What else needs to be additionally purchased for work (not included in the watch kit)

- AC/DC adapter 5V 0.5A (1.0A) - for the main power supply of the watch.
- Battery CR1220 - for backup power DS1307.

Assembly instruction.

A watch can be assembled in a few hours by anyone who knows how to carefully mount DIP parts on a printed circuit board by soldering according to the instructions.

First, install passive components on the circuit board - capacitors, resistors, a clock button, a quartz resonator, and a battery holder.

Places for installing parts on the board are indicated by silk-screen printing. It is worth noting that all parts are installed on the bottom side of the printed circuit board, and LEDs - on the upper side of the printed circuit board. The case of the quartz resonator must be additionally soldered to the printed circuit board.

Designation of components in the circuit board illustration:

100 – 100R, 300 – 300R, 4k7 – 4.7 kOhm, 20k – 20 kOhm, 10k – 10 kOhm

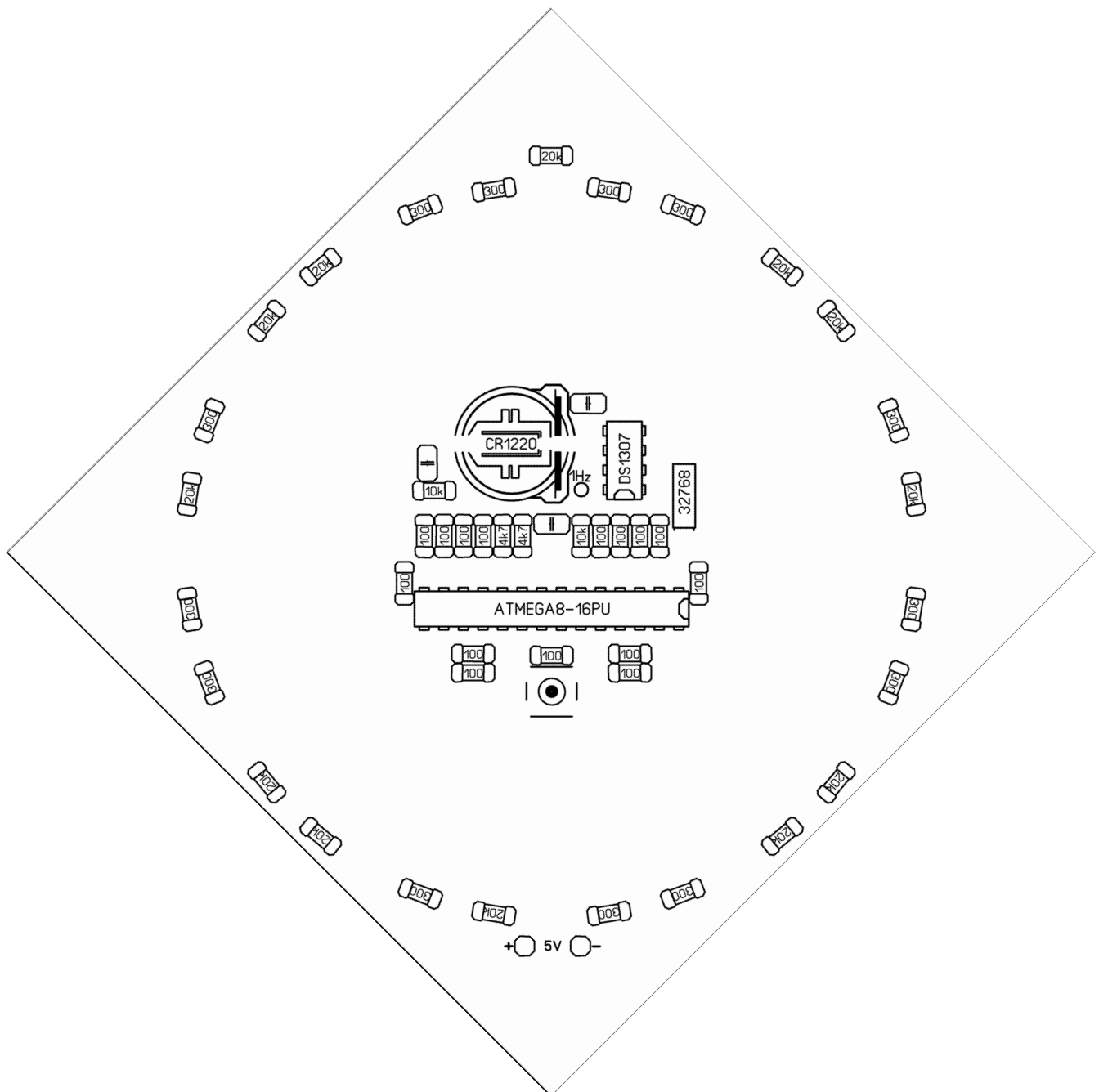

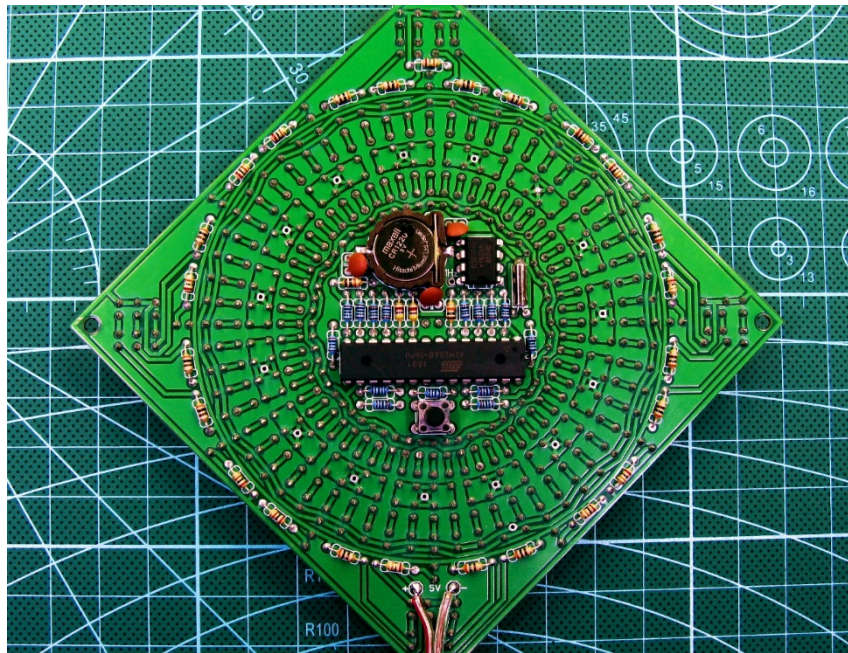

Carefully install and solder passive components on the board.

Then the LEDs of the digit symbols are mounted. They are pressed close to the board, trying not to overheat when soldering. The findings are cut off only after soldering, because they serve as a heat sink and do not allow the crystal to overheat. It is very important not to confuse the polarity of their inclusion, referring to the picture.

LED polarity marking:

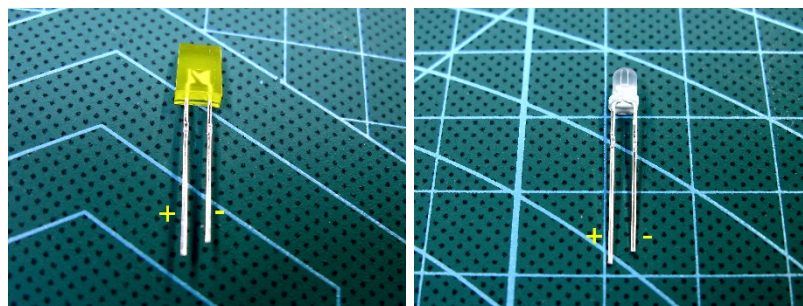

PCB designation:

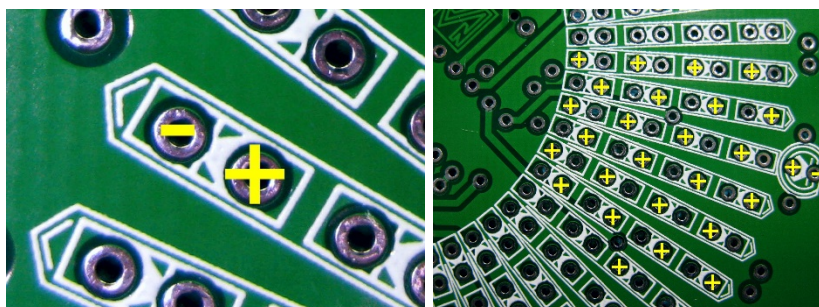

Examples LED Installation:

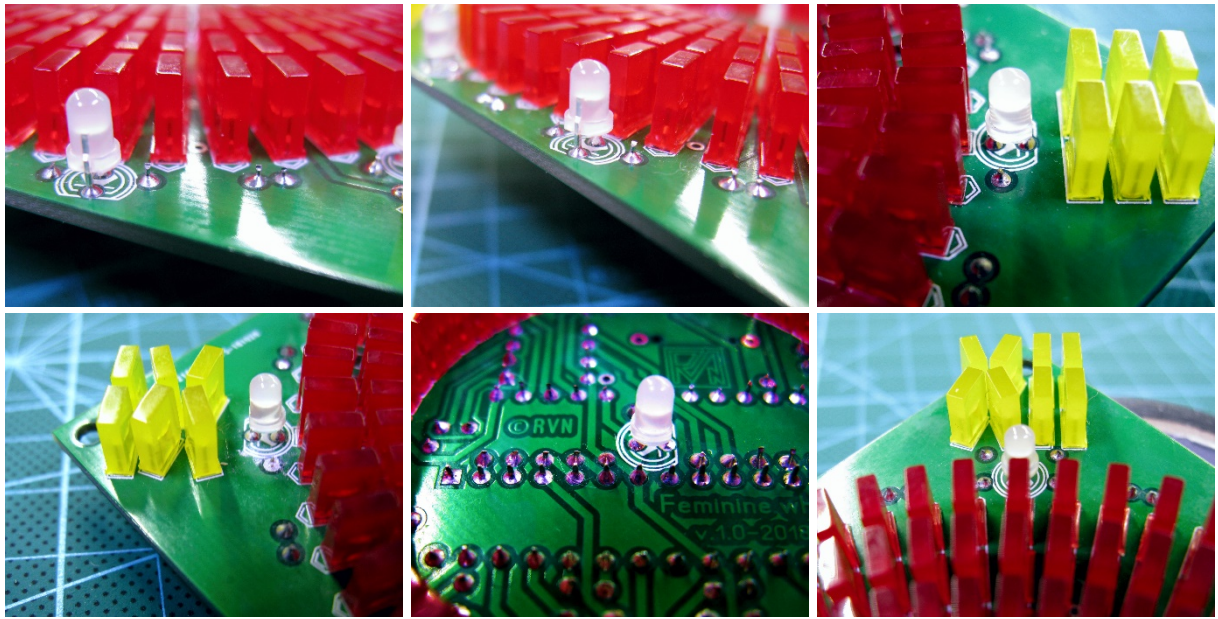

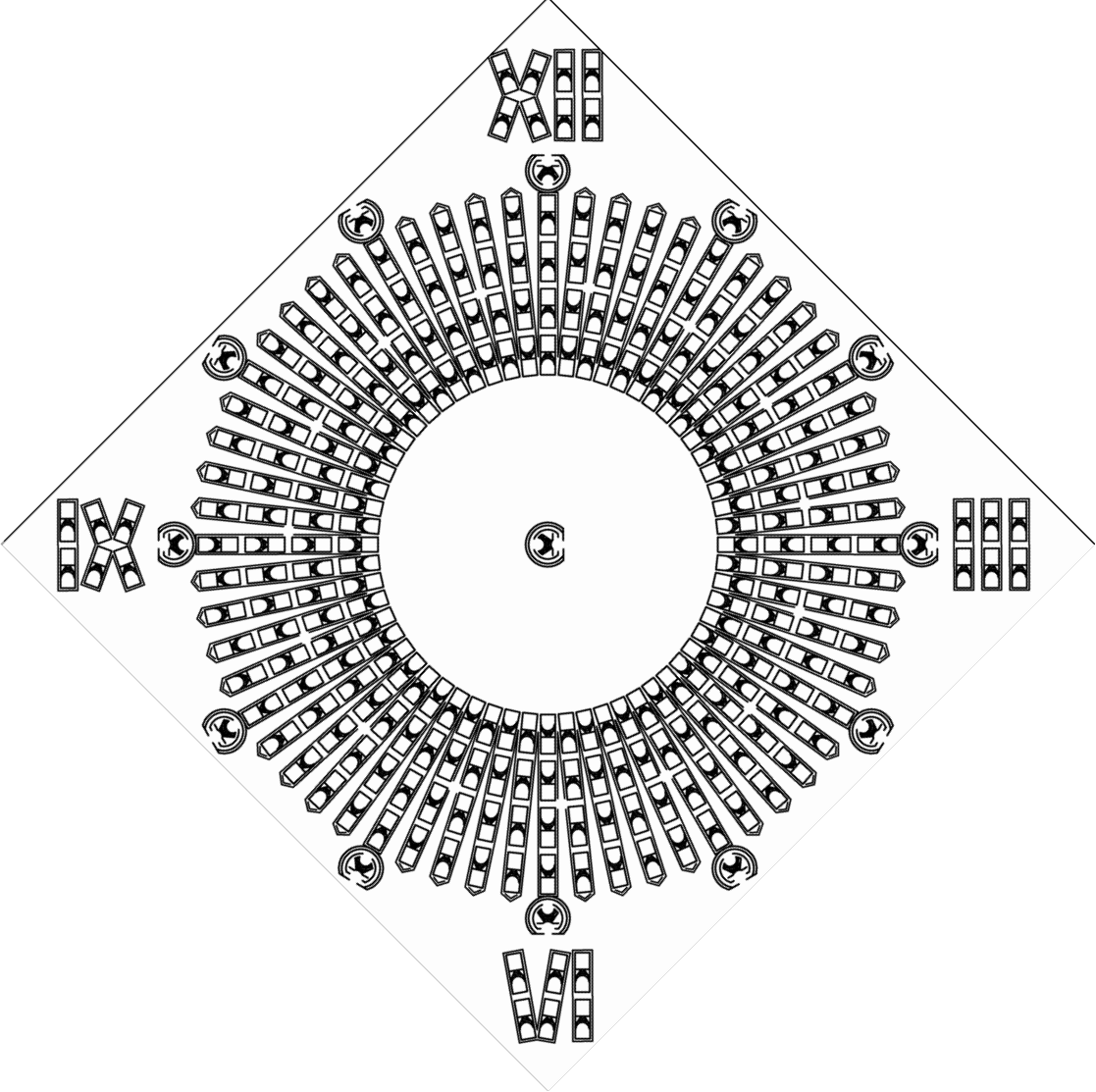
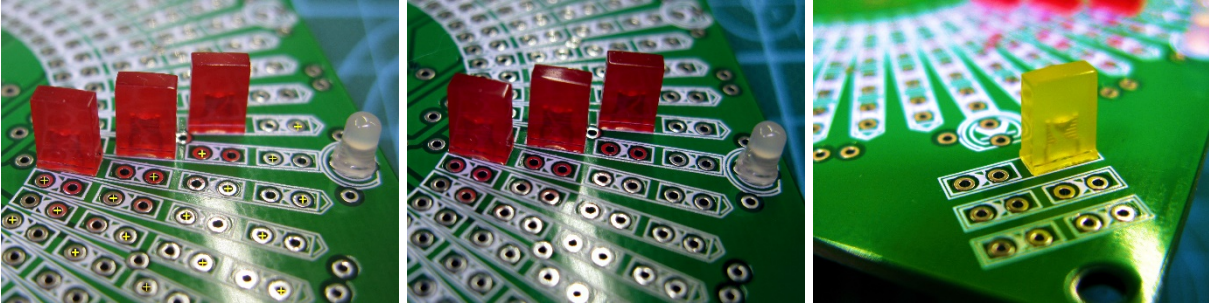

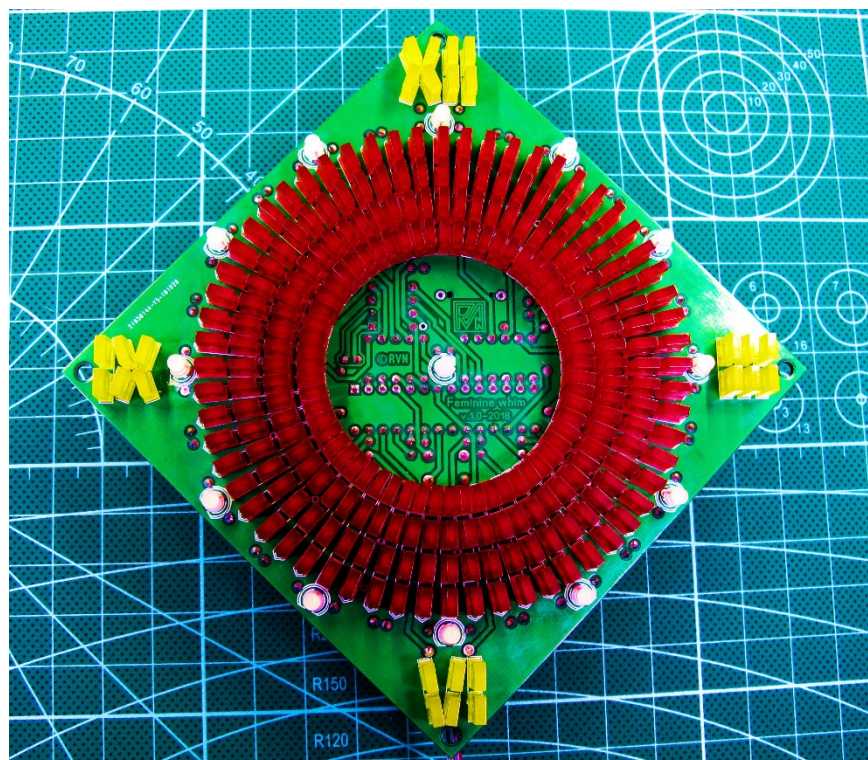

Also, it will be necessary to grind the border of the LEDs in some places with a file so that they become tight to each other. This is relevant for the numbers "V" and "X". You can't rush here, you need to arrange the LEDs in smooth, orderly rows.

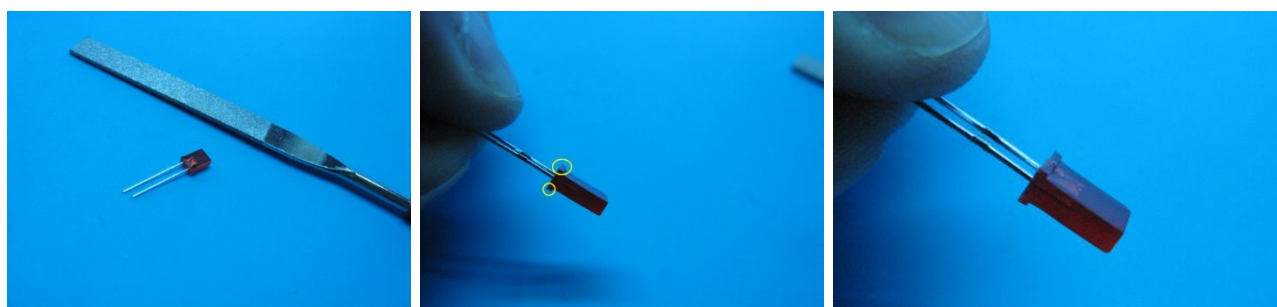

We recommend that at the beginning, to install the LEDs in different corners of the board, this will provide guidelines for further installation of the LEDs in the same plane in height. The printed circuit board is turned upside down, and the LEDs along with the printed circuit board are pressed against the surface of the table. Only then can they be soldered.

Next, you need to insert several LEDs and repeat the operation.

Round LEDs - hour markers and the axis in height is slightly lower than the rectangular LEDs. For a beautiful perception, they also need to be installed in the same plane with rectangular LEDs.

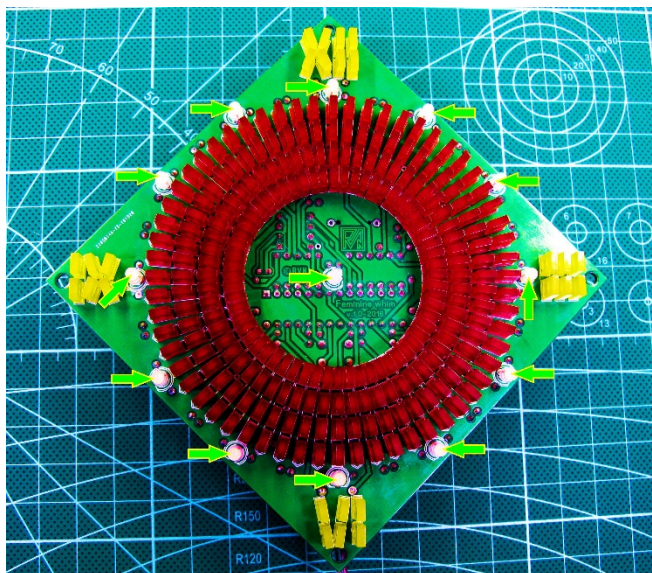

After that, you can apply the supply voltage to the board and make sure that all the digits, LEDs of the hour markers and the axis LED are lit. If no LED is lit, check the operation of the power supply and the polarity of its connection.

Power is connected by soldering at two points located at the bottom of the board, above the number six.

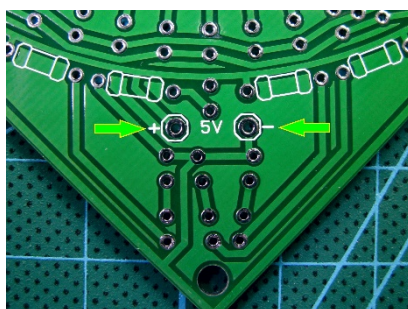

To do this, it is best to take a USB cable, on one side of which there is a “male” type A. On the second side, the connector is cut off, the cable is cut out and there are 2 wires - plus and minus. Usually red is a plus and black is a minus. When connecting to the board, it is also necessary to observe the polarity, and so that the voltage of the power source does not exceed 5 volts.

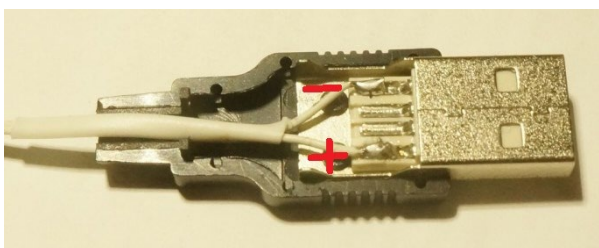

Active components:

Now it's time to install the microcontroller and the clock chip, previously oriented with the key on the case to the key on the board.

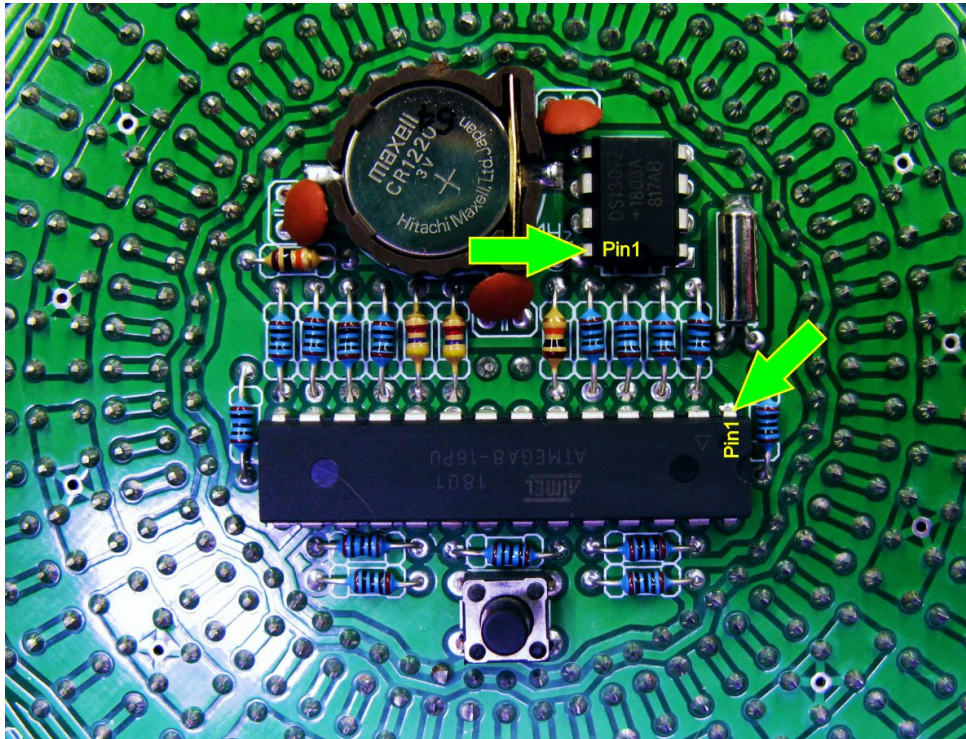

After that, it is necessary to visually inspect the assembled printed circuit board for soldering and short circuit defects. If you suspect a short circuit, you can check the problem areas with a multimeter.

Caution: It is not recommended to use the socket for a clock microcircuit - this will add additional capacity and affect the accuracy of the "progress" of the watch. It is also necessary to thoroughly wash away from the flux residues that part of the board where the quartz and the clock microcircuit are mounted.

Watch dial LEDs:

The next step is to install and solder the LEDs of the main field - the dial. You can't rush here, so as not to confuse the polarity of the inclusion and not to solder crookedly relative to the board and each other. Crookedly soldered LEDs spoil the whole aesthetic appearance. Be sure to check each LED for glow before soldering into the board. It is necessary to mount the LEDs in a single beam, starting from zero minutes. The LEDs of the inner ring need to be modified a little - remove the "skirt" with the help of the file.

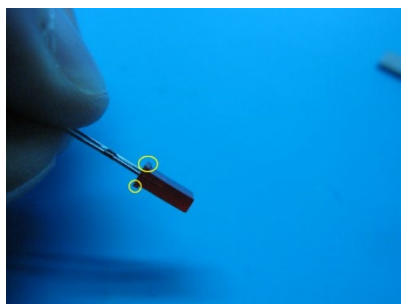

This design feature is caused by the desire to position the inner row of LEDs as close to the center of the axis as possible. After several beams are soldered, you need to make one more test inclusion. If everything is sealed correctly, you will observe a moving second hand in a circle. Thus, the correctness and quality of soldering is visually checked. If something does not work, it is necessary to check the installation again - microcircuits, other components, and of course, LEDs.

Note: Microcontrollers undergo pre-sale training - after filling in the program, they are tested for several hours at the stand. The microcontroller is installed in the ZIF panel and controls the real LEDs.

Next, the power source is turned off and the following rays of the dial LEDs are mounted. After several beams, a test inclusion is again made to verify the installation. When the entire main field is soldered, you need to fully monitor the work of the clock. If necessary, after the installation is completed, the board is washed with alcohol.

Time setting.

Setting the time and selecting the display mode of the second hand is carried out with just one button, which is located on the back of the watch.

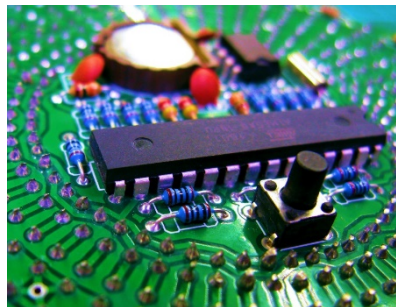

- Short press (less than a second) time synchronization mode (resets seconds).
- Pressing and holding for one second moves the minute hand forward one minute.
- Pressing and holding for two seconds moves the clock hand forward one hour.
- A very long press (more than three seconds) changes the display of the second hand (after turning off the power, the selected seconds mode is saved).

Note: If the clock after power is applied, it starts counting from 00:00:00. This usually happens if the built-in battery loses its capacity. In this case, it must be replaced. The CR1220 lithium battery should theoretically last for a long time (years), because it gives up its energy only when the main power of the watch is turned off.

Attention!

Before connecting the device for the first time, make sure that the polarity of the power supply is correctly connected and that the supply voltage is 5 volts. Incorrect polarity connection can damage the microcontroller and the real-time clock chip.

A properly assembled device does not require configuration and starts working immediately.

Possible causes of malfunction.

The watch is powered from any network adapter with an output voltage of 5 volts. If the watch completely stops glowing, you need to make sure that there is voltage in the outlet, the adapter is working and there is no damage in the power cable.

If only hour markers and numbers are lit, and the hands do not light or do not go, the first suspicion arises of poor-quality soldering of the microcontroller and the clock microcircuit.

If the hands are lit and the clock does not go, the problem is in the DS1307.

If the arrows do not light, the problem is in the controller.

Video of the collected hours

<https://www.youtube.com/watch?v=09XC1EIYTFQ>

P.S.

This watch has been repeatedly assembled by the developer himself, as well as young talents, just picked up a soldering iron. And all with constant success. This is facilitated by high-quality printed circuit boards, pre-sale verification of active components and manufacturing instructions.

Have a good installation!

©RVN 2018-2020

Application 1.

Schematic diagram hours:

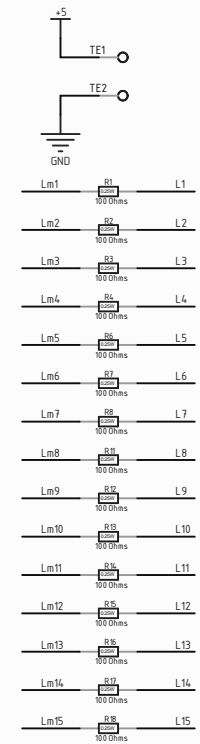
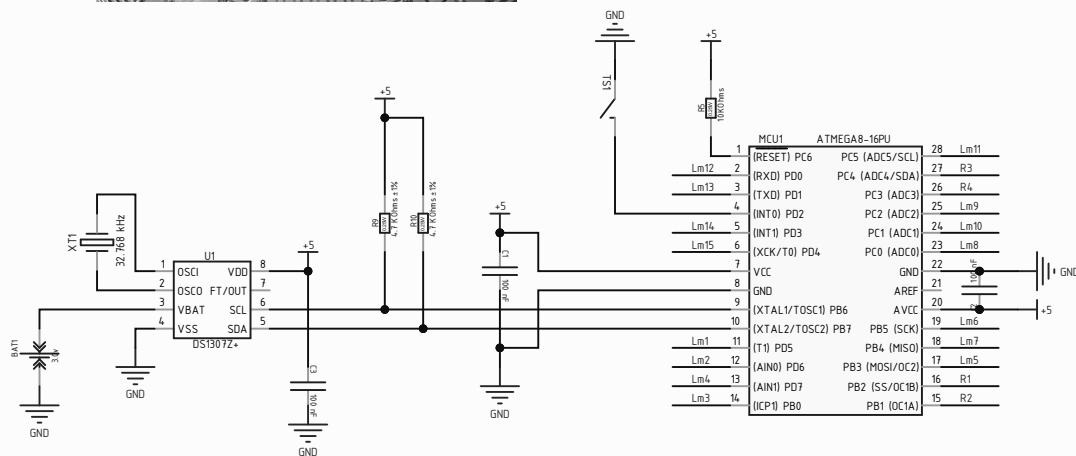
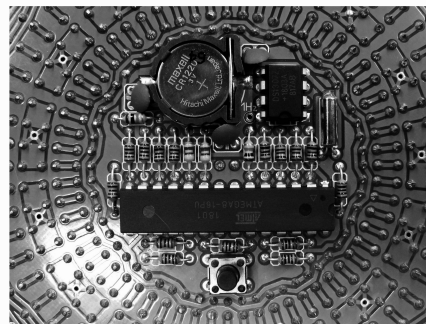

DIY Kit - Awesome Wall-mounted Digital Electronic LED Watch - "Female whim"

Copyright RVN

Title <i>LED Watch - "Female whim"</i>			Catcatcat Electronics Ukraine LISICHANSK RADAN 2020	
Size: A4	Number: 20052401	Revision: 2.3		
Date: 24.05.2020	Time: 20:08:12	Sheet 1 of 2		
File: C:\Project\Project_Altium\ch_svetfomuzyka\2020\Watch_Feminine_Whim\Watch_Feminine_Whim\ra-10001.SchDoc				

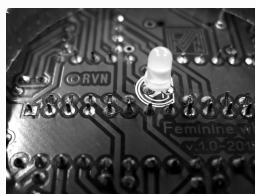
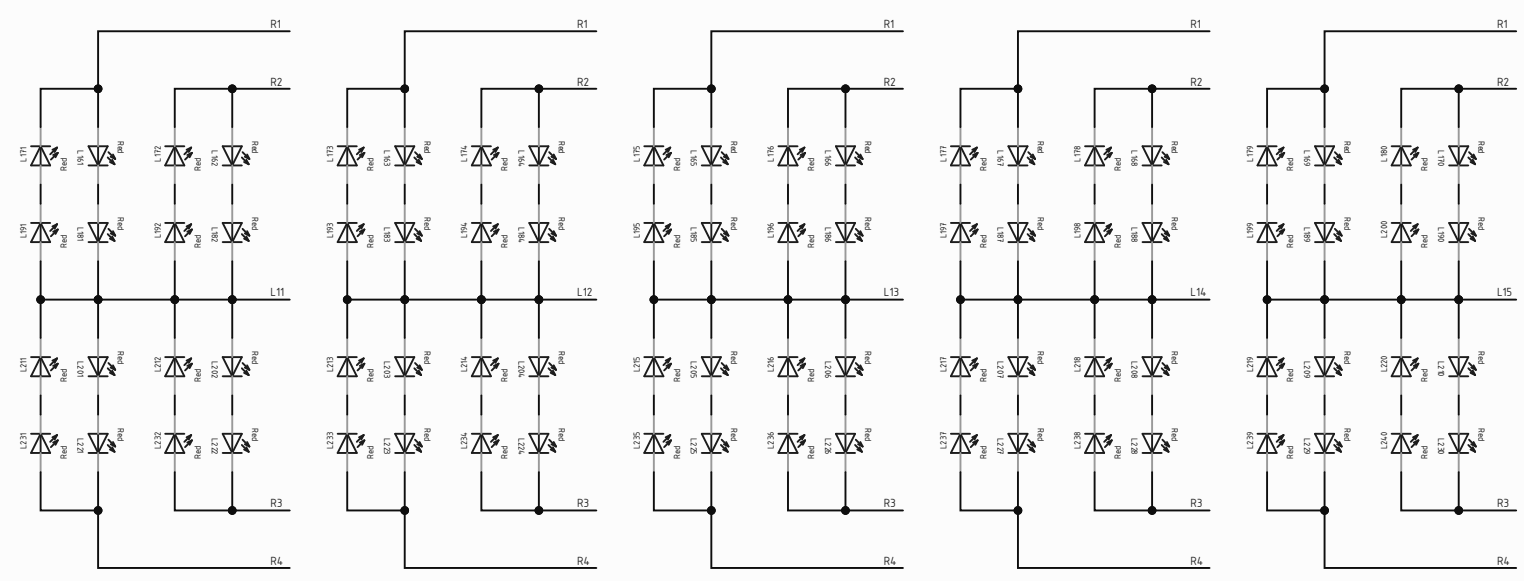
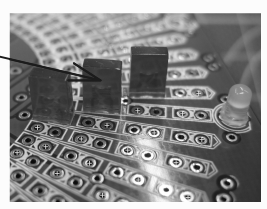
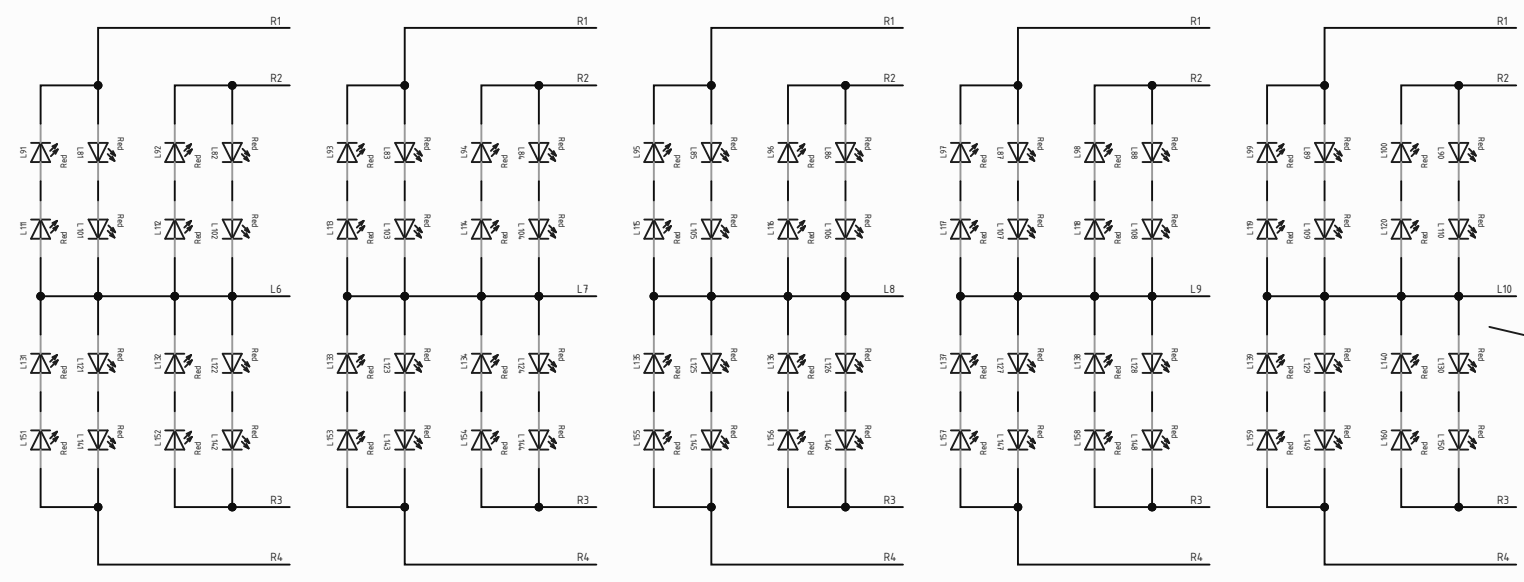
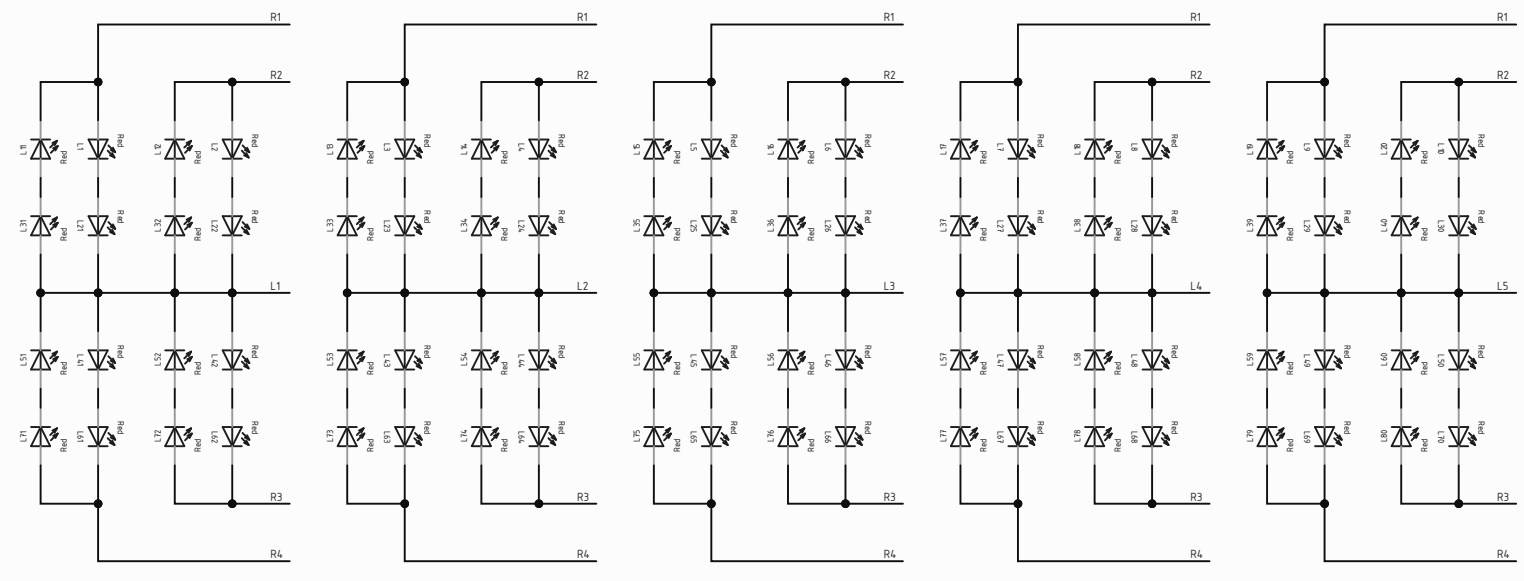

DIY Kit - Awesome Wall-mounted Digital Electronic LED Watch - "Female whim"

Copyright RVN

Title <i>LED Watch - "Female whim"</i>			Catscat Electronics Ukraine	
Size: A3	Number: 20052402	Revision: 2.3	LISICHANSK RADAN	
Date: 24.05.2020	Time: 20:08:14	Sheet 2 of 2	2020	
File: C:\Project\Project_Altium\ch_svetomuzyka\2020\Watch_Feminine_Whim\Watch_Feminine_Whim\LED_matrix.SchDoc				

